

## 2. Vehicle file

### I/ Segmobyl V1

The Segmobyl V1 is an intermediate vehicle that permits commuters to efficiently go from their home to their work. The Segmobyl is a two-in-one option that allows you to do the first km to the periphery of the city, park your vehicle, and finish your trip inside the city center with a smaller and less energy consuming means of transportation, e.g. the segway. It's a solution to commute between rural areas or at least urban periphery to the downtown.

- State of the vehicle: concept
- Type of vehicle: electric
- Amount of people: 1-2
- Max speed: 45 km/h.
- Weight: <250 kg
- Amount of wheels: 2+2

The vehicle is designed with several key features for efficiency and sustainability. It has four wheels for safety and aims to be half the length of a regular vehicle to optimize parking space. The rear wheels are the ones of the Segway, which propel the front part of the vehicle. The passenger compartment is weather-protected using light textile materials. Two swappable batteries, each around 20 kg, offer flexibility for different ranges. The vehicle's maximum speed is 45 km/h. It features two seats and relies on a user's smartphone for GPS and radio, reducing material and energy use. The vehicle is modular, with the Segway being removable for short-distance travel and with dismountable parts for separate battery use, promoting resource efficiency and reducing urban congestion.

## II/ The vehicle - First prototype

- The Segmobyl V1 is a light vehicle with a Dyneema fabric weather protection which covers the passengers.

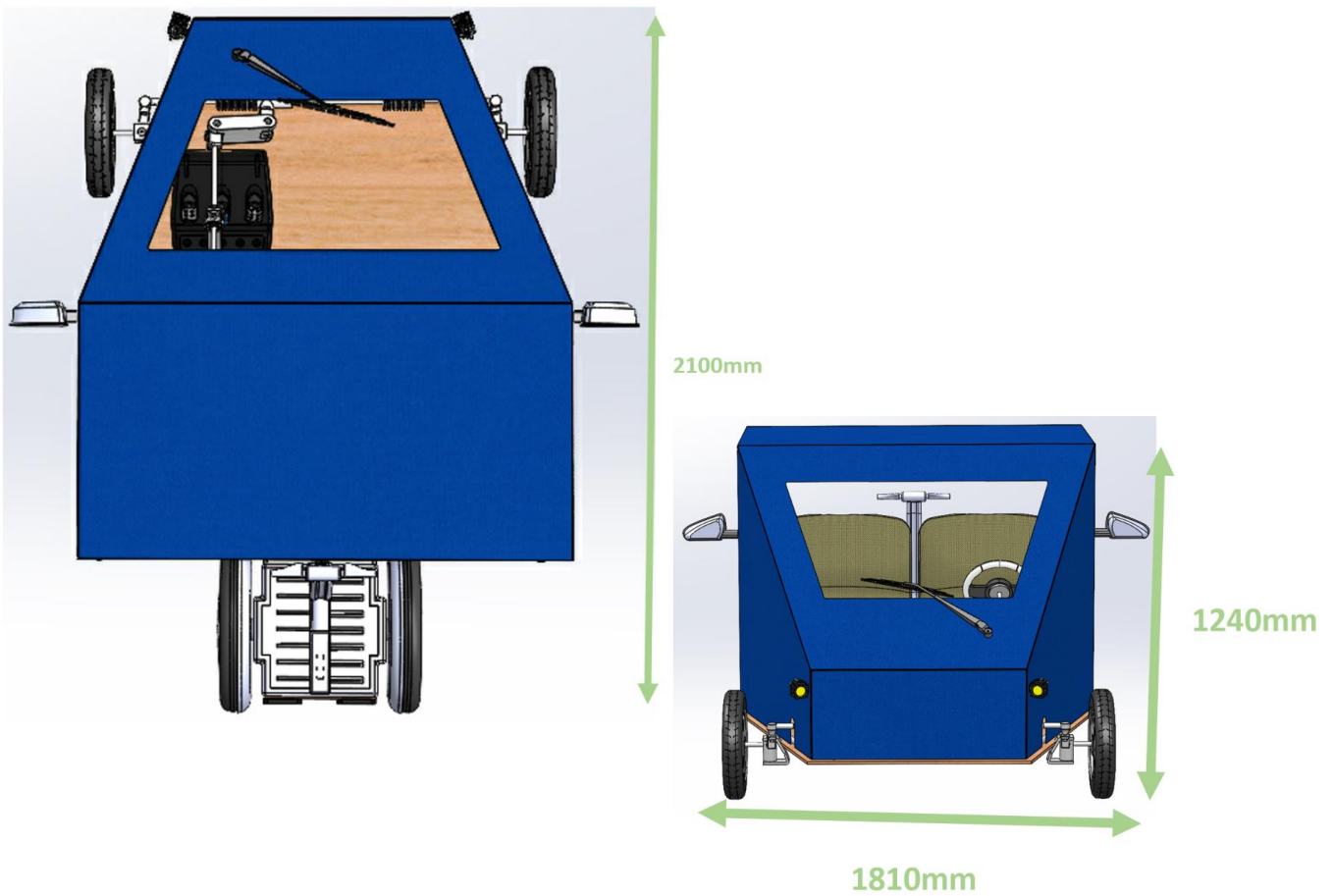

- There is one opening at the back of the vehicle. The outer shell of the vehicle can easily be lifted by one person.
- The vehicle has a minimalist interior, it is composed of a platform, seats, a place for batteries and the minimum elements needed to drive and control the speed of the vehicle.



- A jack at the back of the vehicle allows one to remove the segway when parked.

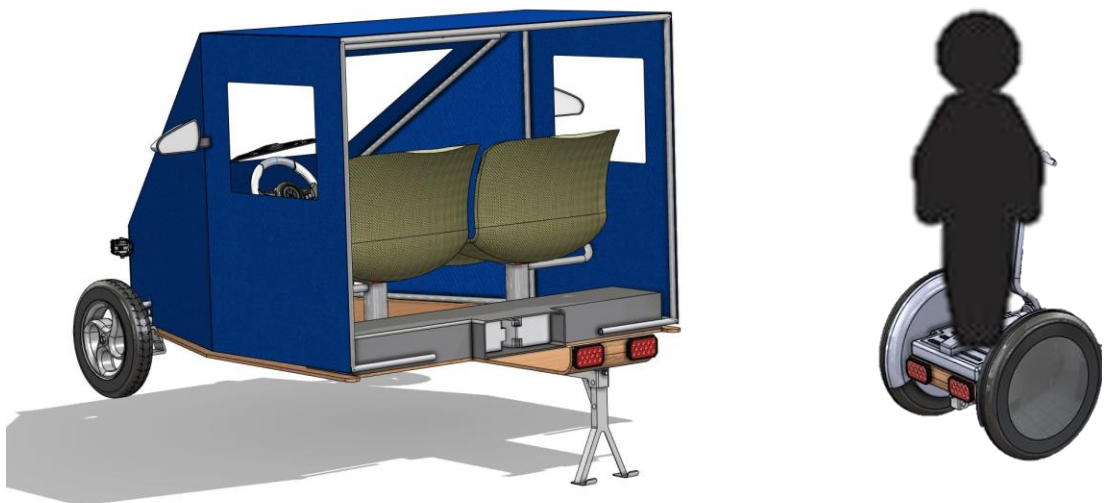

- Under the seats there is room for shopping bags.



Vehicle Parts	Function	Status	Materials	Supplier	Environmental impact/eco conception
Outer structure	Protect the passengers from the weather	Concept	Dyneema and allow for the structure	ALUULA or AVIENT	Recyclable, reusable
Electric motor (if needed)	Will help the segway to propulse the vehicle	Available	To be defined	Not identified yet	
Battery	Energy storage, battery swapping system.	Available	To be defined what battery swapping system we include.	To be defined	Recyclable
Brakes	Disks - stop the vehicle from driving.	Available	Steel and plastic hose	Shimano, Magura, Sram (to be define precisely)	Recyclable
Seats		Available	Recycled plastic	To be defined	Recyclable
Belt	Secure passengers	Available	Polyester	To be defined	Reusable
Steering wheel	Control the trajectory of the vehicle	Available	Second-hand or one material	France casse (second-hand)	Reusable
Wheels	Ensure the transmission between the vehicle and the floor	Prototype	Available from Michelin concept.	Michelin	Recyclable
LED lights	To see during night, be seen and communicate with other drivers	Available	LED	Motorcycle supplier or Cosmo	Recyclable

Vehicle Parts	Function	Status	Materials	Supplier	Environmental impact/eco conception
Outer structure	Protect the passengers from the weather	Concept	Dyneema and allow for the structure	ALUULA or AVIENT	Recyclable, reusable
Electric motor (if needed)	Will help the segway to propulse the vehicle	Available	To be defined	Not identified yet	
Segways	Propulse and be an independent mobility solution for the last kilometers	Available	Different materials	Second hand Segway	Reused
Tubular structure	Rigidify the outer structure	Available	Aluminum or glass fiber rebars	Owens corning or other.	Recyclable, reusable
Bottom platform	To ensure cohesion between all parts of the vehicle.	Available	Wood or flax fiber composites	B-comp or other.	Recyclable, reusable
Shock absorber	Keeps the tyres in contact with the road, increasing safety and comfort.	Available	Steel, aluminum, rubber	Motorcycle supplier	lightweight, recyclable, end-of-life considerations
Transmission system	Transfers the power from the motor to the driveshaft	Available	aluminum or magnesium alloy (housing), high strength steel (gears and others)	Not identified yet	High efficiency, lightweight, recyclable, eco-friendly lubricants
Charging	Connect the	Available	Copper,	Not	Difficult to

Vehicle Parts	Function	Status	Materials	Supplier	Environmental impact/eco conception
Outer structure	Protect the passengers from the weather	Concept	Dyneema and allow for the structure	ALUULA or AVIENT	Recyclable, reusable
Electric motor (if needed)	Will help the segway to propulse the vehicle	Available	To be defined	Not identified yet	
cable	batteries to the charging station to recharge them		PVC, thermoplastic	identified yet	recycle.
Front windscreen	To protect passengers and see where the vehicle go	Available	Polycarbonate	Not identified yet	Recyclable
Mirrors	Visibility	Available	Glass	Not identified yet	Reused
Windows	Weather protection + vision	Available	Polycarbonate or PVC	Not identified yet	Recyclable
Direction transmission	To transfer the commands to the wheels	Available but need to be adapted	Alloy or steel	Not identified yet	Recyclable

The Segmobyl V1 with its different parts identified :

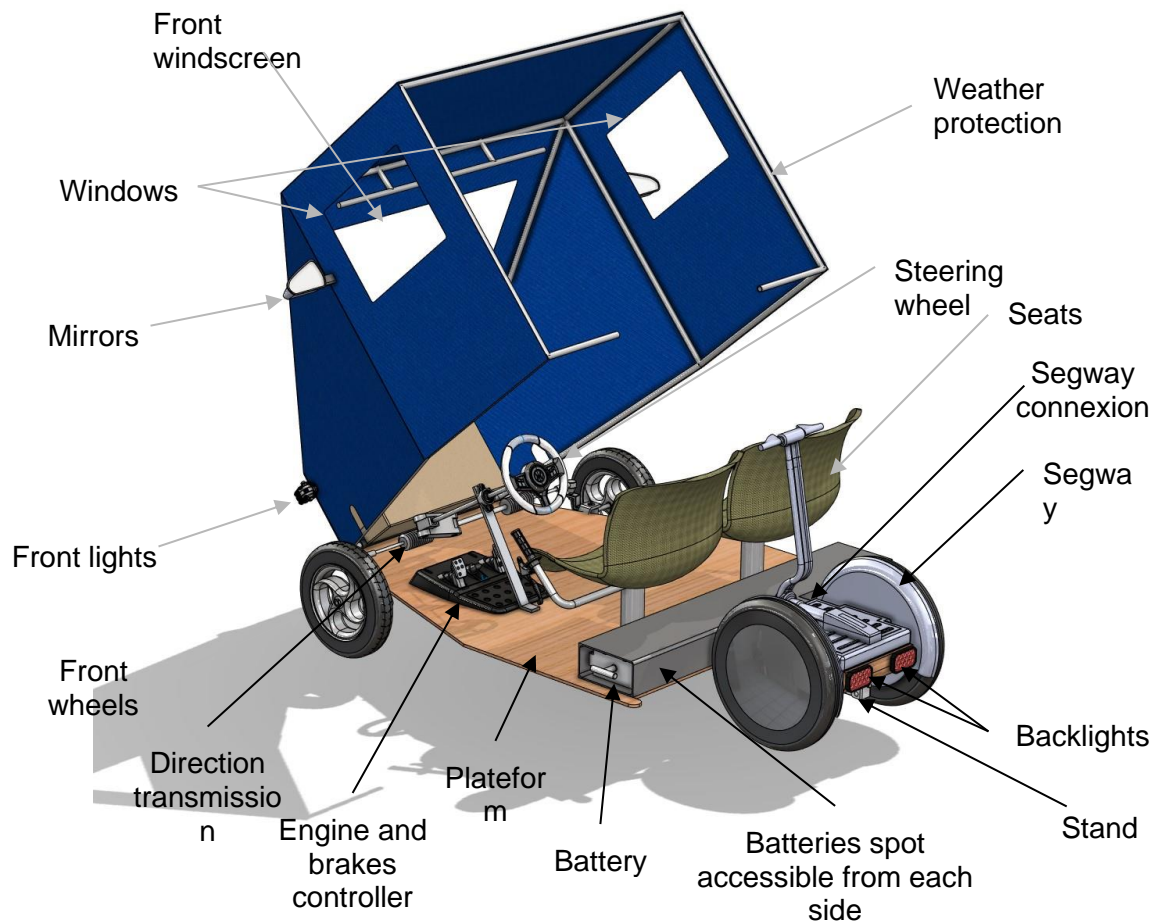

### III/ Segmobyl V2

The Segmobyl V2 is an intermediate vehicle that permits commuters to efficiently go from their home to their work. The Segmobyl V2 is a two-in-one option that allows you to do the first km to the periphery of the city, park your vehicle, and finish your trip inside the city center with a smaller and less energy consuming means of transportation, e.g. the e-scooter. It's a solution to commute between rural areas or from the urban periphery to the downtown.

- State of the vehicle: concept
- Type of vehicle: electric
- Amount of people: 1-3
- Max speed: 45 km/h.
- Weight: <200 kg
- Amount of wheels: 2+2



The vehicle is designed with several key features for efficiency and sustainability. It has four wheels for safety and aims to be lighter than regular vehicles to optimize parking space. The rear wheels are the ones of the e-scooter, which tract the back part of the vehicle. The passenger compartment is weather-protected using light textile materials. Two swappable batteries, each around 15 kg, offer flexibility for different ranges. The vehicle's maximum speed is 45 km/h. It features one pilot seat, a bench seat and relies on a user's smartphone for GPS and radio, reducing material and energy use. The vehicle is modular, with the e-scooter being removable for short-distance travel and with dismountable parts for separate battery use, promoting resource efficiency and reducing urban congestion.

#### IV/ The vehicle - Second prototype

- The Segmobyl V2 is a light vehicle with a Dyneema fabric weather protection which covers the passengers. The fabric is all around the passenger (the roof, left and right side and the back side).

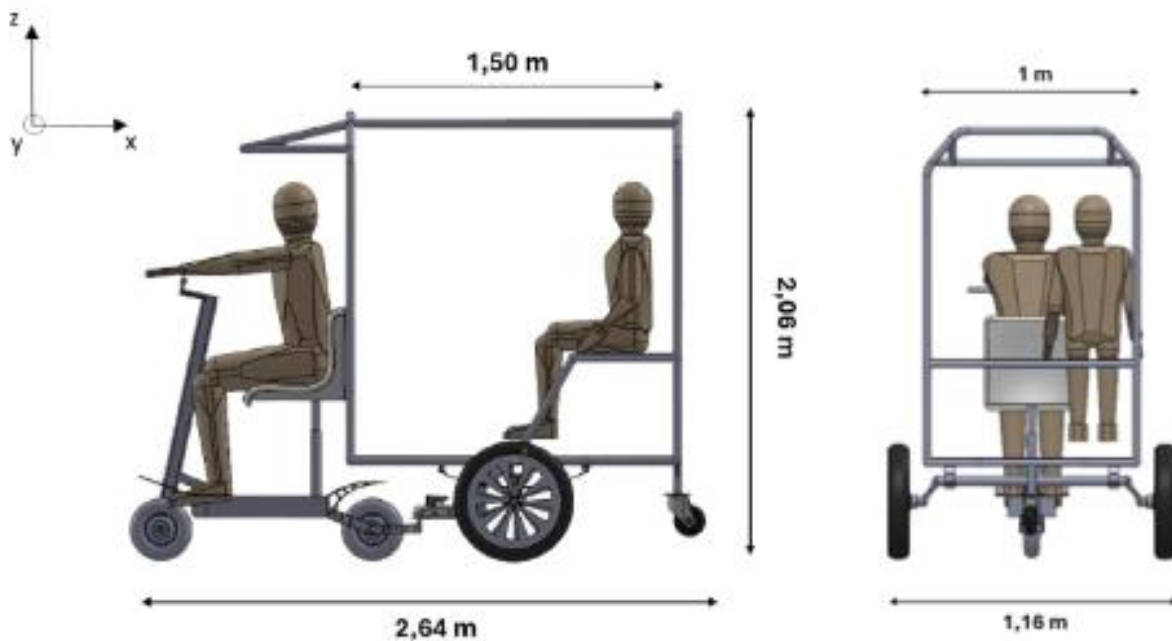

- There is one opening at the front of the vehicle.
- The vehicle has a minimalist interior, it is composed of a platform, seats, a place for batteries and the minimum elements needed to drive and control the speed of the vehicle.



Batteries and  
luggages spot  
(under the  
bench seat)

- A “roue jocket” at the back of the vehicle allows one to remove the e scooter when parked.

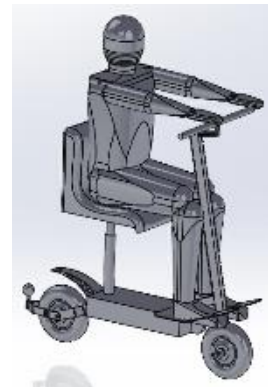

- This “roue jocket” is present at the back of the vehicle to prevent scale of the vehicle during travel also.



Vehicle Parts	Function	Status	Materials	Supplier	Environmental impact/ecoconcepti on.
Outer structure	Protect the passengers from the weather	Concept	Dyneema and allow for the structure	ALUULA or AVIENT	Recyclable, reusable
Battery	Energy storage, battery swapping system.	Available	To be defined what battery swapping system we include.	To be defined	Recyclable
Brakes	Disks - stop the vehicle from driving.	Available	Steel and plastic hose	Shimano, Magura, Sram or tailer brakes manufacturer (to be define precisely)	Recyclable
Pilot seat		Available	Recylcled plastic	To be defined	Recyclable
Bench seat		Concept	sheep's wool and leather or textile		Recyclable
Belt	Secure passengers	Available	Polyester	To be defined	Reusable
Wheels	Ensure the transmission between the vehicle and the floor	Prototype	Available from Michelin concept.	Michelin	Recyclable
LED lights	To see during night, be seen and communicate with other drivers	Available	LED	Motorcycle supplier or Cosmo	Recyclable
E scooter	Tract, pilot	Available	Different	Second hand	Reused

Vehicle Parts	Function	Status	Materials	Supplier	Environmental impact/ecoconception.
Outer structure	Protect the passengers from the weather	Concept	Dyneema and allow for the structure	ALUULA or AVIENT	Recyclable, reusable
	and be an independent mobility solution for the last kilometers		materials	e scooter (for a certain type of e scooter)	
Tubular structure	Rigidify the outer structure	Available	Aluminum or glass fiber rebars	Owens corning or other.	Recyclable, reusable
Bottom platform	To ensure cohesion between all parts of the vehicle.	Available	Wood or flax fiber composites	B-comp or other.	Recyclable, reusable
Shock absorber	Keeps the tyres in contact with the road, increasing safety and comfort.	Available	Steel, aluminum	Motorcycle supplier / inspire from truck shocks	lightweight, recyclable, end-of-life considerations
Charging cable	Connect the batteries to the charging station to recharge them	Available	Copper, PVC, thermoplastic	Not identified yet	Difficult to recycle.
Mirrors	Visibility	Available	Glass	Not identified yet	Reused
Windows	Weather protection + vision	Available	Polycarbonate or PVC	Not identified yet	Recyclable
Footrest	Have a support in	Design	Steel	To be define	Recyclable

Vehicle Parts	Function	Status	Materials	Supplier	Environmental impact/ecoconception.
Outer structure	Protect the passengers from the weather	Concept	Dyneema and allow for the structure	ALUULA or AVIENT	Recyclable, reusable
	braking situation				

The Segmobyl V2 with its different parts identified :

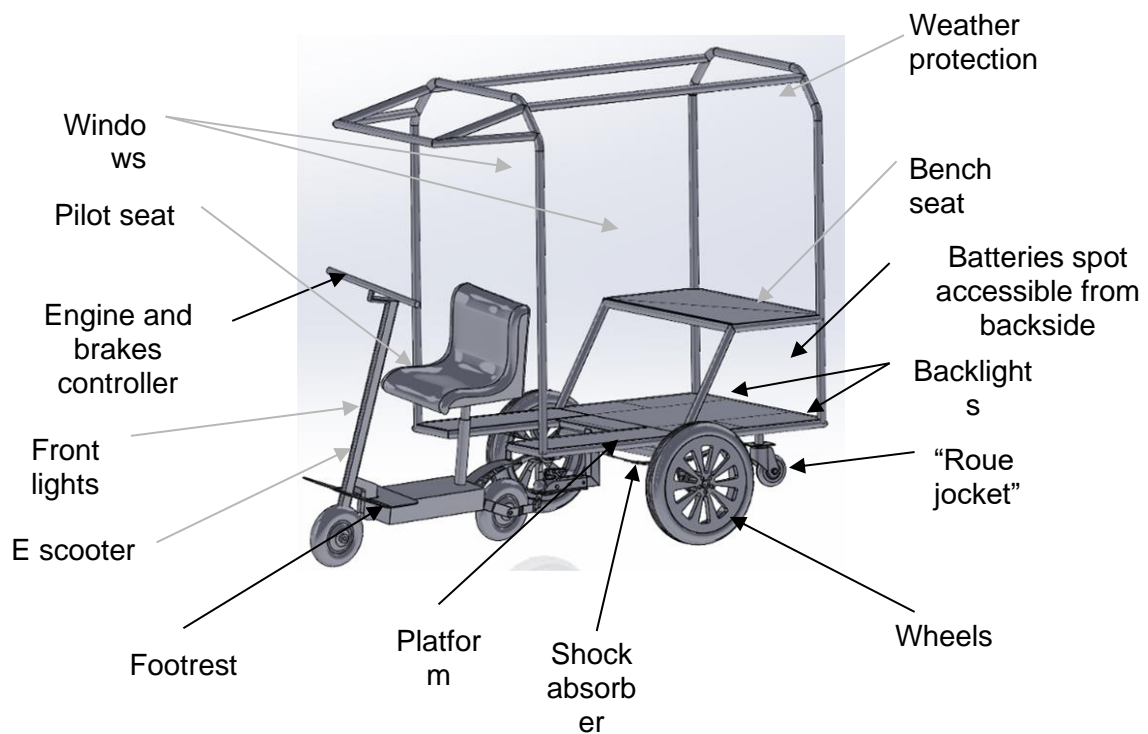

The CAD and STEPS files are available here :

- SegmobyI V1 : [https://drive.google.com/drive/folders/1cOxsNBVzZ6FCEYmPEXgt2TbQ7KM3vVY6?usp=drive\\_link](https://drive.google.com/drive/folders/1cOxsNBVzZ6FCEYmPEXgt2TbQ7KM3vVY6?usp=drive_link)
- SegmobyI V2 : <https://drive.google.com/file/d/1D6-Y5logEwHLQM1uuVku-vahynXQUNe8/view?usp=sharing>